



Doosan Infracore  
Construction Equipment

# DX140W TECHNICAL DATA





## GENERAL SPECIFICATIONS

ITEMS		UNIT	STANDARD
ENGINE	MODEL		Doosan DL06 Diesel, Tier III Certified
	NUMBER OF CYLINDERS		6
	RATED FLYWHEEL POWER (hp PER SAE J1995) GROSS	hp / rpm	134 / 2,000
		kW / rpm	100 / 2,000
	RATED FLYWHEEL POWER (hp PER SAE J1349) NET	hp / rpm	125 / 2,000
		kW / rpm	94 / 2,000
	MAXIMUM TORQUE (GROSS) (SAE J1995)	ft. lb. / rpm	398 / 1,400
		Nm / rpm	539 / 1,400
	PISTON DISPLACEMENT	in. <sup>3</sup>	359
		cc	5,890
	BORE AND STROKE	in. x in.	3.9 x 4.9
mm x mm		100 x 125	
STARTER	V / kW	24 V, 4.5 kW	
BATTERIES	V / AH	2 x 12 V x 100 AH	
AIR CLEANER		Double element with auto dust evacuation.	
MAIN PUMPS – 2 VARIABLE DISPLACEMENT AXIAL PISTON PUMPS MAX FLOW	US gpm	2 x 41.2	
	L / min.	2 x 156.1	
PILOT PUMP (GEAR DESIGN)	MAXIMUM FLOW	US gpm	4.9
		L / min.	18.5
	RELIEF PRESSURE	psi	569
		bar	39
MAXIMUM SYSTEM PRESSURE	BOOM/ARM/BUCKET (NORMAL MODE)	psi	4,694
		bar	324
	BOOM/ARM/BUCKET (POWER MODE)	psi	4,978
		bar	343
	TRAVEL	psi	4,978
		bar	343
SWING	psi	3,485	
	bar	240	
ENVIRONMENT	SOUND LEVEL (2000/14/EC)	dB(A)	101
	CABIN SOUND LEVEL (ISO 6396)	dB(A)	74
SWING MECHANISM	SWING SPEED	rpm	0 - 11.3
DRIVE SYSTEM	TRAVEL SPEED (FAST/SLOW)	mph	23
		km / h.	37
	DRAWBAR PULL	lb.	16,975
		kg	7,700
	MAXIMUM GRADE	%	70
		°	35

# DX140W

ITEMS		UNIT	STANDARD
REFILL CAPACITIES	FUEL TANK	US gal.	74
		L	280
	COOLING SYSTEM (RADIATOR CAPACITY)	qt.	21
		L	20
	ENGINE OIL	qt.	23
		L	22
	SWING DRIVE	qt.	2.1
		L	2
	FRONT AXLE	qt.	2.6
		L	2.5
	REAR AXLE	qt.	2.5
		L	2.4
	TRANSMISSION	qt.	2.6
		L	2.5
	HYDRAULIC SYSTEM	US gal.	41
		L	155
HYDRAULIC TANK	US gal.	27	
	L	102	

## WEIGHT

<b>BOOM</b>	<b>14' 1" (4,300 mm) One-Piece or 11' 6" + 6' 1" (3,500 mm + 1,850 mm) Two-Piece</b>		
<b>ARM</b>	<b>6' 11" (2,100 mm)</b>		
<b>BUCKET</b>	<b>0.77 yd.<sup>3</sup> (0.59 m<sup>3</sup>)</b>		
<b>UNDERCARRIAGE TYPE</b>		<b>OPERATING WEIGHT (ONE-PIECE BOOM)</b>	<b>OPERATING WEIGHT (TWO-PIECE BOOM)</b>
<b>FRONT ATTACHMENT</b>	<b>REAR ATTACHMENT</b>		
CRADLE	DOZER	30,313 lb. (13,750 kg)	31,508 lb. (14,292 kg)
CRADLE	OUTRIGGER	31,036 lb. (14,078 kg)	32,231 lb. (14,620 kg)
DOZER	OUTRIGGER	32,315 lb. (14,658 kg)	33,510 lb. (15,200 kg)
OUTRIGGER	DOZER	32,374 lb. (14,685 kg)	33,569 lb. (15,227 kg)
OUTRIGGER	OUTRIGGER	33,398 lb. (15,013 kg)	34,292 lb. (15,555 kg)



## HYDRAULIC CYLINDERS

The piston rods and cylinder bodies are made of high-strength steel. A shock absorbing mechanism is fitted in all cylinders to ensure shock-free operation and extend piston life.

[One-Piece Boom]			[Two-Piece Boom]		
CYLINDERS	QUANTITY	BORE x ROD DIAMETER x STROKE	CYLINDERS	QUANTITY	BORE x ROD DIAMETER x STROKE
BOOM	2	4.3" x 3.0" x 3' 5" (110 x 75 x 1,048 mm)	BOOM	2	4.3" x 3.0" x 3' 5" (110 x 75 x 1,048 mm)
ARM	1	4.5" x 3.1" x 3' 6" (115 x 80 x 1,075 mm)	ARM	1	4.5" x 3.1" x 3' 6" (115 x 80 x 1,075 mm)
BUCKET	1	3.7" x 2.6" x 2' 11" (95 x 65 x 900 mm)	BUCKET	1	3.7" x 2.6" x 2' 11" (95 x 65 x 900 mm)

## DIGGING FORCE (ISO)

BUCKET (PCSA)	0.31 yd. <sup>3</sup> (0.24 m <sup>3</sup> )	0.51 yd. <sup>3</sup> (0.39 m <sup>3</sup> )	0.59 yd. <sup>3</sup> (0.45 m <sup>3</sup> )	0.67 yd. <sup>3</sup> (0.51 m <sup>3</sup> )	0.77 yd. <sup>3</sup> (0.59 m <sup>3</sup> )	0.84 yd. <sup>3</sup> (0.64 m <sup>3</sup> )	0.99 yd. <sup>3</sup> (0.76 m <sup>3</sup> )	0.55 yd. <sup>3</sup> (0.42 m <sup>3</sup> ) HD	0.64 yd. <sup>3</sup> (0.49 m <sup>3</sup> ) HD	0.70 yd. <sup>3</sup> (0.54 m <sup>3</sup> ) HD
DIGGING FORCE	22,355 lbf	22,355 lbf	22,355 lbf	22,355 lbf	22,355 lbf	22,355 lbf	22,355 lbf	22,355 lbf	22,355 lbf	22,355 lbf
	10,140 kgf	10,140 kgf	10,140 kgf	10,140 kgf	10,140 kgf	10,140 kgf	10,140 kgf	10,140 kgf	10,140 kgf	10,140 kgf
	99.5 kN	99.5 kN	99.5 kN	99.5 kN	99.5 kN	99.5 kN	99.5 kN	99.5 kN	99.5 kN	99.5 kN

ARM	6' 11" (2,100 mm)	8' 2" (2,500 mm)
DIGGING FORCE	16,865 lbf	14,440 lbf
	7,650 kgf	6,550 kgf
	75 kN	64 kN



## BUCKET

CAPACITY		WIDTH		WEIGHT	RECOMMENDATIONS				
SAE, HEAPED	CECE, HEAPED	WITHOUT SIDE CUTTERS	WITH SIDE CUTTERS		14' 1" (4,300 mm) ONE-PIECE BOOM	15' 1" (4,600 mm) ONE-PIECE BOOM		16' 4" (4,988 mm) TWO-PIECE BOOM	
0.31 yd. <sup>3</sup> (0.24 m <sup>3</sup> )	0.29 yd. <sup>3</sup> (0.22 m <sup>3</sup> )	18.4" (468 mm)	21.0" (534 mm)	648 lb. (294 kg)	A	A	A	A	A
0.51 yd. <sup>3</sup> (0.39 m <sup>3</sup> )	0.46 yd. <sup>3</sup> (0.35 m <sup>3</sup> )	30.0" (736 mm)	32.4" (820 mm)	798 lb. (362 kg)	A	A	B	A	B
0.59 yd. <sup>3</sup> (0.45 m <sup>3</sup> )	0.52 yd. <sup>3</sup> (0.40 m <sup>3</sup> )	32.4" (824 mm)	35.9" (911 mm)	886 lb. (402 kg)	A	B	B	B	B
0.67 yd. <sup>3</sup> (0.51 m <sup>3</sup> )	0.59 yd. <sup>3</sup> (0.45 m <sup>3</sup> )	35.7" (907 mm)	39.0" (991 mm)	922 lb. (418 kg)	B	B	C	B	C
0.77 yd. <sup>3</sup> (0.59 m <sup>3</sup> )	0.67 yd. <sup>3</sup> (0.51 m <sup>3</sup> )	39.3" (997 mm)	42.6" (1,081 mm)	968 lb. (439 kg)	B	C	C	C	-
0.84 yd. <sup>3</sup> (0.64 m <sup>3</sup> )	0.72 yd. <sup>3</sup> (0.55 m <sup>3</sup> )	42.6" (1,083 mm)	45.9" (1,167 mm)	1,025 lb. (465 kg)	C	C	-	C	-
0.99 yd. <sup>3</sup> (0.76 m <sup>3</sup> )	0.85 yd. <sup>3</sup> (0.65 m <sup>3</sup> )	44.1" (1,120 mm)	48.0" (1,220 mm)	1,144 lb. (519 kg)	C	-	-	-	-
0.55 yd. <sup>3</sup> (0.42 m <sup>3</sup> ) HD	0.50 yd. <sup>3</sup> (0.38 m <sup>3</sup> )	30.0" (762 mm)	32.6" (827 mm)	2,147 lb. (974 kg)	B	C	C	C	-
0.64 yd. <sup>3</sup> (0.49 m <sup>3</sup> ) HD	0.58 yd. <sup>3</sup> (0.44 m <sup>3</sup> )	33.4" (848 mm)	35.9" (913 mm)	2,319 lb. (1,052 kg)	C	C	-	C	-
0.70 yd. <sup>3</sup> (0.54 m <sup>3</sup> ) HD	0.63 yd. <sup>3</sup> (0.48 m <sup>3</sup> )	36.0" (916 mm)	38.6" (981 mm)	2,416 lb. (1,096 kg)	C	-	-	-	-

A. Suitable for materials with density of 2,000 kg•m<sup>3</sup> (3,370 lb./yd.<sup>3</sup>) or less

B. Suitable for materials with density of 1,600 kg•m<sup>3</sup> (2,700 lb./yd.<sup>3</sup>) or less

C. Suitable for materials with density of 1,100 kg•m<sup>3</sup> (1,850 lb./yd.<sup>3</sup>) or less

# DIMENSIONS

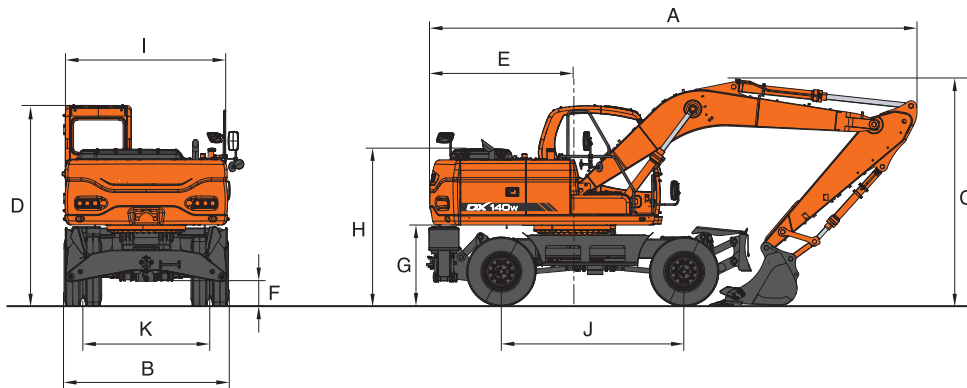

		[ONE-PIECE BOOM]		
BOOM TYPE		14' 1" (4,300 mm)	15' 1" (4,600 mm)	
ARM TYPE		6' 11" (2,100 mm)	6' 11" (2,100 mm)	8' 2" (2,500 mm)
SHIPPING LENGTH	A	23' 9" (7,235 mm)	25' 8" (7,820 mm)	24' 6" (7,470 mm)
SHIPPING WIDTH	B	8' 2" (2,496 mm)	←	←
SHIPPING HEIGHT (BOOM)	C	11' (3,351 mm)	10' 7" (3,225 mm)	11' 4" (3,460 mm)
HEIGHT OVER CAB.	D	10' (3,040 mm)	←	←
C/WEIGHT SWING CLEARANCE	E	7' 3" (2,200 mm)	←	←
GROUND CLEARANCE	F	1' 2" (350 mm)	←	←
COUNTER WEIGHT CLEARANCE	G	4' (1,206 mm)	←	←
ENGINE COVER HEIGHT	H	7' 10" (2,376 mm)	←	←
UPPER HOUSING WIDTH	I	8' 2" 2,494 mm)	←	←
WHEEL BASE	J	9' 2" (2,800 mm)	←	←
TREAD WIDTH	K	6' 5" (1,944 mm)	←	←

# DX140W

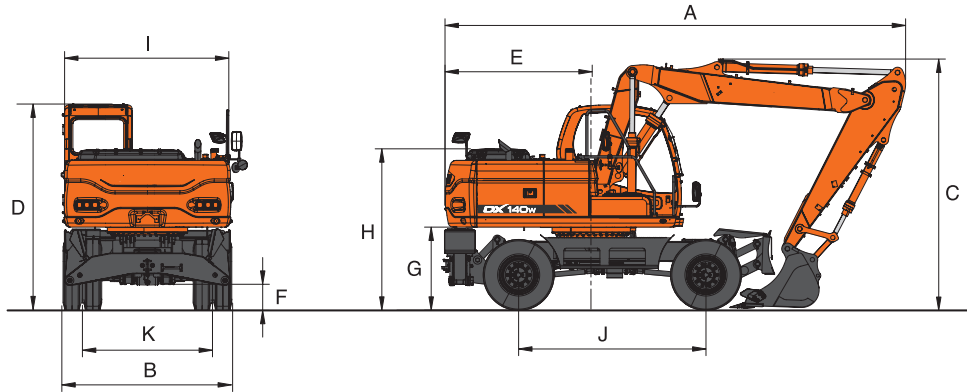

[TWO-PIECE BOOM]			
BOOM TYPE		16' 4" (4,988 mm)	
ARM TYPE		6' 11" (2,100 mm)	8' 2" (2,500 mm)
SHIPPING LENGTH	A	23' 1" (7,030 mm)	22' 7" (6,885 mm)
SHIPPING WIDTH	B	8' 2" (2,496 mm)	←
SHIPPING HEIGHT (BOOM)	C	12' (3,650 mm)	12' 3" (3,730 mm)
HEIGHT OVER CAB.	D	10' (3,040 mm)	←
C/WEIGHT SWING CLEARANCE	E	7' 3" (2,200 mm)	←
GROUND CLEARANCE	F	1' 2" (350 mm)	←
COUNTER WEIGHT CLEARANCE	G	4' (1,206 mm)	←
ENGINE COVER HEIGHT	H	7' 10" (2,376 mm)	←
UPPER HOUSING WIDTH	I	8' 2" (2,494 mm)	←
WHEEL BASE	J	9' 2" (2,800 mm)	←
TREAD WIDTH	K	6' 5" (1,944 mm)	←

# WORKING RANGE

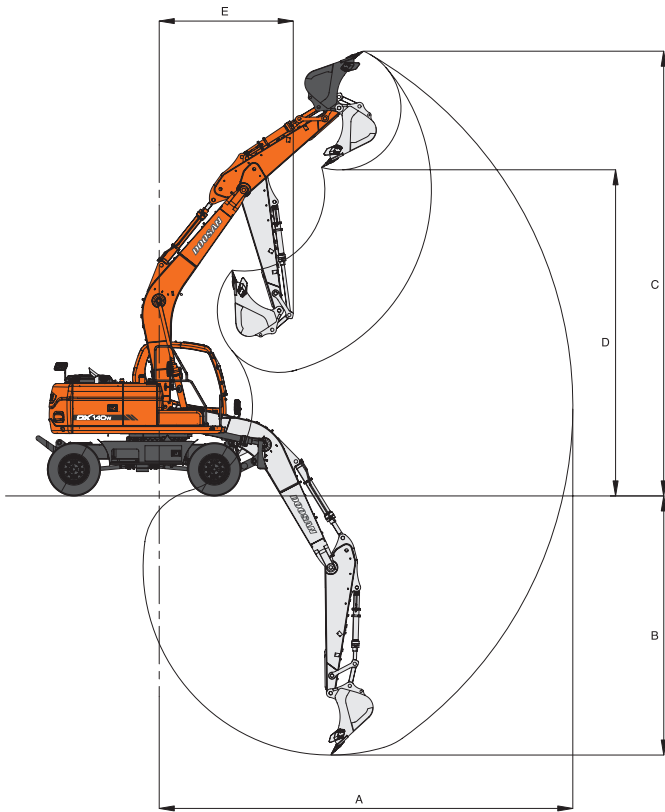

[ONE-PIECE BOOM]				
BOOM TYPE		14' 1" (4,300 mm)	15' 1" (4,600 mm)	
ARM TYPE		6' 11" (2,100 mm)	6' 11" (2,100 mm)	8' 2" (2,500 mm)
MAX. DIGGING RADIUS	A	24' 8" (7,520 mm)	25' 7" (7,790 mm)	27' 1" (8,250 mm)
MAX. DIGGING DEPTH	B	15' (4,580 mm)	15' 9" (4,790 mm)	17' (5,190 mm)
MAX. DIGGING HEIGHT	C	26' 8" (8,130 mm)	27' 6" (8,370 mm)	29' (8,850 mm)
MAX. DUMP HEIGHT	D	19' 1" (5,810 mm)	19' 11" (6,060 mm)	21' 3" (6,480 mm)
MIN. SWING RADIUS	E	8' 1" (2,470 mm)	8' 5" (2,570 mm)	8' 9" (2,670 mm)

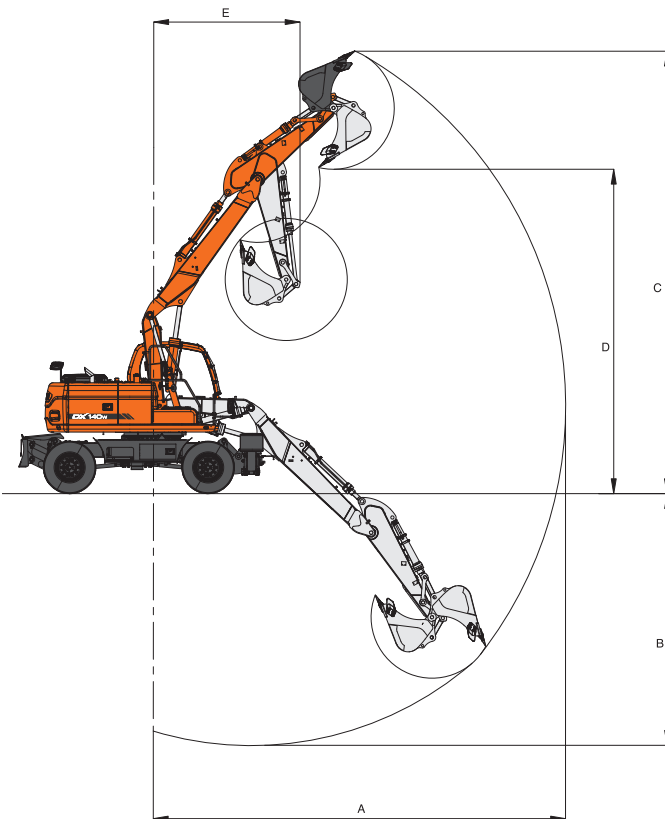

[TWO-PIECE BOOM]			
BOOM TYPE		16' 4" (4,988 mm)	
ARM TYPE		6' 11" (2,100 mm)	8' 2" (2,500 mm)
MAX. DIGGING RADIUS	A	27' 4" (8,330 mm)	28' 8" (8,750 mm)
MAX. DIGGING DEPTH	B	16' 10" (5,120 mm)	18' 2" (5,530 mm)
MAX. DIGGING HEIGHT	C	29' 11" (9,110 mm)	31' 3" (9,520 mm)
MAX. DUMP HEIGHT	D	22' (6,700 mm)	23' 4" (7,100 mm)
MIN. SWING RADIUS	E	9' 4" (2,840 mm)	9' 5" (2,860 mm)

## NOTES

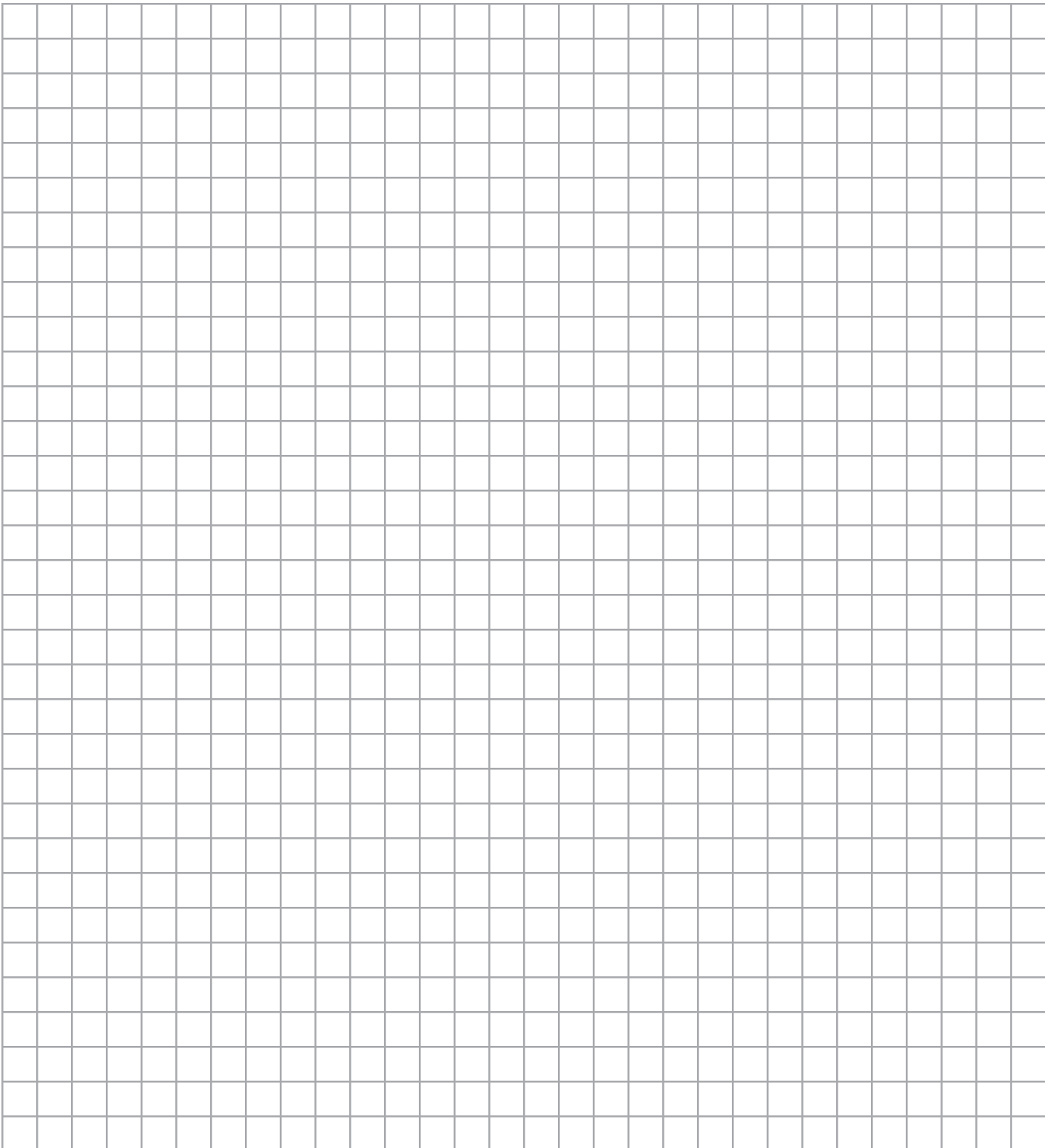
A large grid of graph paper for taking notes, consisting of 20 columns and 30 rows of small squares.





## STANDARD EQUIPMENT

### ENGINE:

DOOSAN DL06:

Electronically Controlled Common Rail Direct Injected  
359 cu.in., 6 Cylinder  
125 SAE Net Flywheel Horsepower @ 2,000 rpm  
Automatic Idling System  
Radiator Reserve Tank  
Electronic Engine Speed Control  
Engine Overheat Prevention System

### HYDRAULIC SYSTEM:

Pilot Operated (2) Control Valves  
Main Pump, Bent Axis Axial Piston Type,  
Pressure Setting 4,978 PSI  
Pilot Circuit, Gear Type Pump  
Swing Motor, Axial Piston Type  
Swing Speed Control up to 11.3 rpm  
Swing Safety Lock - Manual Pin Locking  
Travel Motors, Hydrostatic Drive  
Automatic Travel Speed Control  
Travel Speed up to 23.0 mph  
Parking Brake  
Cross Sensing & Fuel Saving Pump Control  
Computer-Aided Engine-Pump Control  
e-EPOS (Electronic Power Optimizing System) Controller

### CAB:

Steel, All Weather  
Air Conditioner with Heater, R134a Refrigerant  
Multi-Function Color LCD Monitor Panel  
Cigarette Lighter with Ashtray  
Door Locks  
Front Windshield Wiper with Washer  
Radio:  
AM/FM Stereo with Cassette  
Remote Radio On/Off Switch,  
Control Volume, Channel Selection  
Safety Glass, Tinted  
Safety Lock Lever

### Seat:

Suspension with Seat Belt (2" Wide)  
Reclining  
Height Adjustable  
Adjustable Arm Rests  
Sliding Control Console  
Weight Adjustment Knob  
Skylight  
Pull Up Type Front Window and Removable Lower Front Window  
Sliding Side Windows  
Fuel Control Dial  
Front Window Air Defroster  
Travel Pedals with Hand Levers  
Emergency Breakout Tool  
Lunch Box with Hot & Cool Air  
12V Spare Socket  
Joystick Lever with 3 Switches  
Cup Holder  
Room Light  
Serial Communication Port for Laptop PC Interface  
Viscous Cab Mounts

### ELECTRICAL:

Alternator:  
60 Amp  
Batteries:  
(2) 12V, 100 Amp Hrs. 750 CCA ea.  
Starter:  
24V, 4.5 kW  
Horn  
Hour Meter  
Lights:  
Front: (2) Machine, (2) Boom  
Alarm Buzzer for:  
Transmission Overheat  
Engine Oil Pressure

Electronic Monitor for:

- Engine Coolant Temperature Gauge
- Fuel Gauge
- Hydraulic Oil Temperature Gauge

Multi-Function Display for:

- Engine rpm
- Battery Voltage
- Front and Rear Hydraulic Pump Pressure
- Hydraulic Oil Overheating Warning
- Fuel Shortage Warning
- Air Filter Clogging Warning
- Pilot Filter Clogging Warning
- Return Filter Clogging Warning
- Digital Clock
- Engine Check Warning Light
- Engine Oil Pressure Warning Light
- Charging Warning Light
- Preheat Light
- Coolant Temperature Warning Light
- Work Light Indicator Light
- Power Mode Switches
- Trenching Mode Selector Button
- Flow Control Button
- Auto Idle Switch

**UNDERCARRIAGE:**

10.00 x 20 (14PR) Dual Wheels

(2) Outriggers - Front

(1) Dozer Blade - Rear

Transmission:

2-speed, Power shift

Front & Rear Axle, Floating Planetary Drive

**OTHER STANDARD EQUIPMENT:**

Air Cleaner

Counterweight, 4,850 lb. (2,200 kg)

Sealed Pins, Boom and Bucket Linkages

Swing Mechanism, Internal Gear and Pinion

Centralized Lube Points

Steering Mechanism, Internal Gear and Pinion

Manuals:

Parts and Operator's

Punched Metal Anti-Slip Plates

Engine Overheat Prevention System

Engine Restart Prevention System

GPS with 1 Year Subscription



## OPTIONAL EQUIPMENT

### HYDRAULIC KITS – FACTORY INSTALLED

Single Acting Breaker Kit

Double Acting Thumb Kit

### ADDITIONAL OPTIONS – FACTORY INSTALLED

Air Suspension Seat

CD Player

Work Lights (2 Front Mounted on Cab)

Work Lights (4 Front 2 Rear Mounted on Cab)

Rotating Beacon (Mounted on Cab)

24V, 80A Alternator

Swing Alarm

Electric Fuel Supply Pump

Dozer Blade: 102" W, 23" H (for 24" Shoe)

Rain Shield

DX140W Front Outriggers

Falling Objects Guard Assembly Kit

Lock Valve

### GEITH COUPLERS – DEALER INSTALLED

Hydraulic Quick Coupler

Manual Quick Coupler

### GEITH THUMBS – DEALER INSTALLED

Hydraulic Pro Link Thumb

Mechanical Thumb

### HYDRAULIC KITS – DEALER INSTALLED

Breaker Kit (B) Single Acting HKX

Thumb Kit (T) Double Acting HKX Piping Ends at Boom Tip

Breaker / Thumb Kit (BT) Single & Double Acting HKX

### ADDITIONAL OPTIONS – DEALER INSTALLED

3" Seat Belt

Vandalism Covers

## LIFTING CAPACITY (ONE-PIECE BOOM)

Boom: 14'1" (4,300 mm)

Arm: 6'11" (2,100 mm)

Counterweight: 2.40 ton (2.18 metric ton)

Front OT Down + Rear OT Down

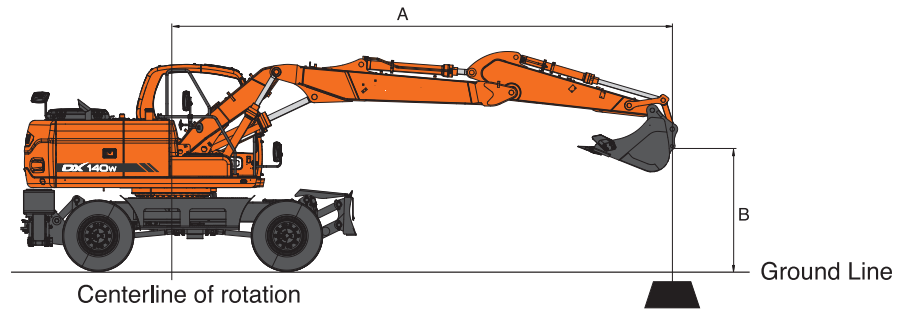

Feet Unit: 1,000 lb.

B (ft.) \ A (ft.)	10		15		20		MAX. REACH		A (ft.)
20							6.11*	6.11*	14.76
15			11.25*	11.25*			5.63*	5.63*	18.39
10	19.18*	19.18*	13.79*	13.79*	6.44*	6.44*	5.71*	5.71*	20.16
5	24.87*	24.87*	15.93*	15.14	9.25*	9.25*	6.21*	6.21*	20.59
0 (GROUND)	25.66*	25.66*	16.88*	14.84			7.36*	7.36*	19.77
-5	23.15*	23.15*	15.64*	14.8			10.08*	10.08*	17.50
-10	16.20*	16.20*					11.89*	11.89*	13.04

Metric Unit: 1,000 kg

B (m) \ A (m)	2		3		4		5		6		MAX. REACH		A (m)
6											2.75*	2.75*	4.59
5							3.93*	3.93*			2.58*	2.58*	5.36
4					6.00*	6.00*	5.22*	5.22*			2.54*	2.54*	5.86
3			8.94*	8.94*	6.93*	6.93*	5.93*	5.93*	3.55*	3.55*	2.59*	2.59*	6.16
2					7.89*	7.89*	6.43*	5.99	4.54*	4.5	2.72*	2.72*	6.28
1			9.97*	9.97*	8.58*	8.55	6.82*	5.89	4.86*	4.45	2.95*	2.95*	6.23
0 (GROUND)			11.11*	11.11*	8.82*	8.45	6.97*	5.83	3.63*	3.63*	3.34*	3.34*	6.03
-1	8.04*	8.04*	11.23*	11.23*	8.55*	8.42	6.72*	5.81			4.01*	4.01*	5.63
-2	11.83*	11.83*	9.93*	9.93*	7.66*	7.66*	5.44*	5.44*			5.35*	5.35*	5.00
-3			7.60*	7.60*	5.52*	5.52*					5.42*	5.42*	4.03

1. Load point is the end of the arm
2. Capacities marked with an asterisk (\*) are limited by hydraulic capacities
3. Lift capacities shown do not exceed 75% of minimum tipping loads or 87% of hydraulic capacities
4. The least stable position is over the side
5. The total mass of machine is 14,500 kg included in this mass boom 4.30 m, arm 2.10 m, 2,175 kg counterweight, bucket weight 0 kg all operating fluids a 75 kg operator.
6. Lift capacities are in compliance with ISO 10567

: Rating Over Front

: Rating Over Side or 360 degree



# LIFTING CAPACITY (ONE-PIECE BOOM)

Boom: 15'1" (4,600 mm)

Arm: 6'11" (2,100 mm)

Counterweight: 2.40 ton (2.18 metric ton)

Front OT Down + Rear OT Down

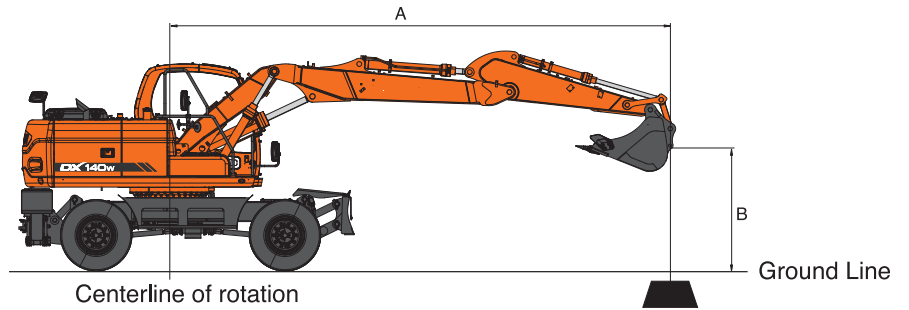

Feet Unit: 1,000 lb.

B (ft.) \ A (ft.)	10		15		20		MAX. REACH		A (ft.)
20			8.67*	8.67*			6.66*	6.66*	16.02
15			11.75*	11.75*			6.29*	6.29*	19.40
10	20.08*	20.08*	13.77*	13.77*	10.05*	9.74	6.44*	6.44*	21.10
5			15.88*	14.99	12.15*	9.55	7.03*	7.03*	21.51
0 (GROUND)	18.67*	18.67*	16.74*	14.68	12.28*	9.43	8.30*	8.30*	20.72
-5	22.69*	22.69*	15.67*	14.65			11.19*	10.54	18.57
-10	16.82*	16.82*					11.43*	11.43*	14.44

Metric Unit: 1,000 kg

B (m) \ A (m)	2		3		4		5		6		MAX. REACH		A (m)
6											3.00*	3.00*	4.96
5							4.68*	4.68*			2.87*	2.87*	5.69
4					6.04*	6.04*	5.39*	5.39*	3.62*	3.62*	2.85*	2.85*	6.16
3					7.01*	7.01*	5.88*	5.88*	4.96*	4.53	2.92*	2.92*	6.44
2					7.96*	7.96*	6.39*	5.94	5.49*	4.47	3.08*	3.08*	6.56
1					8.58*	8.45	6.77*	5.84	5.67*	4.41	3.34*	3.34*	6.52
0 (GROUND)			8.11*	8.11*	8.75*	8.36	6.91*	5.77	5.67*	4.38	3.77*	3.77*	6.31
-1	6.57*	6.57*	10.97*	10.97*	8.47*	8.33	6.72*	5.75			4.49*	4.45	5.94
-2	9.97*	9.97*	9.78*	9.78*	7.69*	7.69*	6.01*	5.78			5.41*	5.23	5.35
-3			7.84*	7.84*	6.09*	6.09*					5.21*	5.21*	4.46

1. Load point is the end of the arm
2. Capacities marked with an asterisk (\*) are limited by hydraulic capacities
3. Lift capacities shown do not exceed 75% of minimum tipping loads or 87% of hydraulic capacities
4. The least stable position is over the side
5. The total mass of machine is 14500 kg included in this mass boom 4.60 m, arm 2.10 m, 2175 kg counterweight, bucket weight 0 kg all operating fluids a 75 kg operator.
6. Lift capacities are in compliance with ISO 10567

: Rating Over Front  
: Rating Over Side or 360 degree



# DX140W

Boom: 15'1" (4,600 mm)

Arm: 8'2" (2,500 mm)

Counterweight: 2.41 ton (2.18 metric ton)

Front OT Down + Rear OT Down

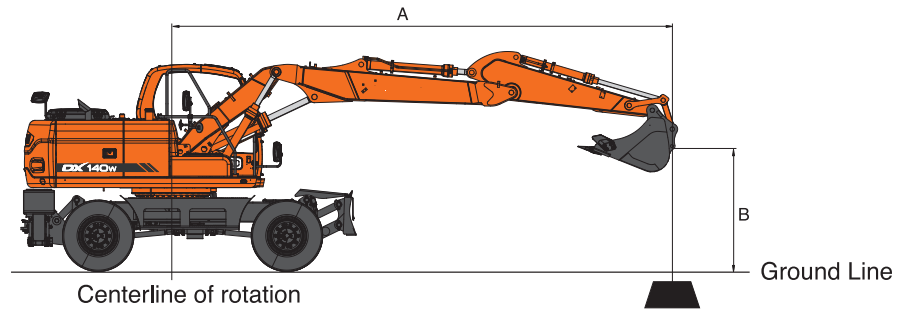

Feet Unit: 1,000 lb.

B (ft.) \ A (ft.)	10		15		20		MAX. REACH		
									A (ft.)
20							4.72*	4.72*	17.99
15			9.59*	9.59*	6.74*	6.74*	4.41*	4.41*	21.04
10	18.11*	18.11*	12.94*	12.94*	9.61*	9.61*	4.43*	4.43*	22.62
5			15.31*	15.04	11.82*	9.55	4.71*	4.71*	23.00
0 (GROUND)	18.01*	18.01*	16.60*	14.66	12.28*	9.39	5.36*	5.36*	22.26
-5	23.79*	23.79*	16.10*	14.56	8.61*	8.61*	6.70*	6.70*	20.29
-10	18.93*	18.93*	12.76*	12.76*			10.35*	10.35*	16.62

Metric Unit: 1,000 kg

B (m) \ A (m)	2		3		4		5		6		7		MAX. REACH		
															A (m)
7													2.36*	2.36*	4.60
6							3.37*	3.37*					2.13*	2.13*	5.56
5							3.98*	3.98*	2.75*	2.75*			2.02*	2.02*	6.21
4					5.01*	5.01*	4.66*	4.66*	3.75*	3.75*			1.99*	1.99*	6.64
3			8.45*	8.45*	6.53*	6.53*	5.56*	5.56*	4.56*	4.54			2.01*	2.01*	6.90
2					7.56*	7.56*	6.13*	5.96	5.30*	4.47	2.15*	2.15*	2.08*	2.08*	7.01
1			7.21*	7.21*	8.34*	8.34*	6.60*	5.84	5.55*	4.41			2.22*	2.22*	6.97
0 (GROUND)			7.83*	7.83*	8.69*	8.35	6.85*	5.76	5.66*	4.36			2.43*	2.43*	6.79
-1	5.76*	5.76*	9.92*	9.92*	8.60*	8.3	6.81*	5.72	5.52*	4.34			2.78*	2.78*	6.44
-2	8.31*	8.31*	10.42*	10.42*	8.04*	8.04*	6.35*	5.73					3.37*	3.37*	5.90
-3	11.54*	11.54*	8.79*	8.79*	6.84*	6.84*	5.10*	5.10*					4.61*	4.61*	5.10

1. Load point is the end of the arm
2. Capacities marked with an asterisk (\*) are limited by hydraulic capacities
3. Lift capacities shown do not exceed 75% of minimum tipping loads or 87% of hydraulic capacities
4. The least stable position is over the side
5. The total mass of machine is 14600 kg included in this mass boom 4.60 m, arm 2.50 m, 2175 kg counterweight, bucket weight 0 kg all operating fluids a 75 kg operator.
6. Lift capacities are in compliance with ISO 10567

: Rating Over Front

: Rating Over Side or 360 degree



# LIFTING CAPACITY (TWO-PIECE BOOM)

Upper Boom: 11'6" (3,500 mm)  
 Lower Boom: 6'1" (1,850 mm)  
 Arm: 6'11" (2,100 mm)  
 Counterweight: 2.40 ton (2.18 metric ton)  
 Front OT Down + Rear OT Down

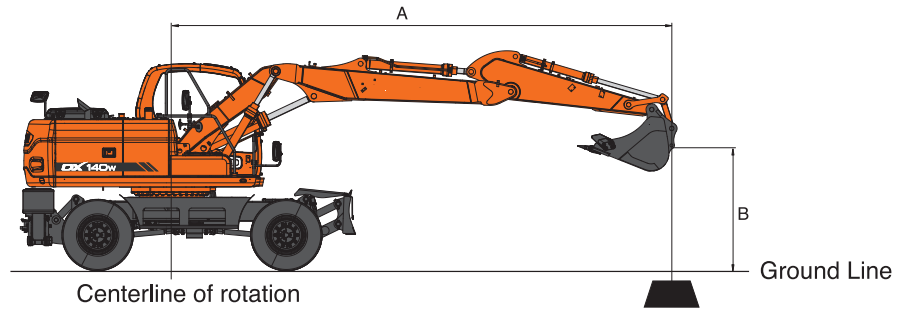

Feet Unit: 1,000 lb.

B (ft.) \ A (ft.)	10		15		20		MAX. REACH		A (ft.)
20							5.39*	5.39*	18.31
15			9.92*	9.92*	8.85*	8.85*	4.98*	4.98*	21.33
10			12.25*	12.25*	10.07*	9.73	4.95*	4.95*	22.88
5			14.68*	14.68*	11.15*	9.48	5.19*	5.19*	23.26
0 (GROUND)			16.07*	14.5	11.91*	9.32	5.79*	5.79*	22.53
-5	19.89*	19.89*	16.05*	14.46	11.64*	9.34	7.05*	7.05*	20.58

Metric Unit: 1,000 kg

B (m) \ A (m)	3		4		5		6		7		MAX. REACH		A (m)
7											2.71*	2.71*	4.72
6					4.07*	4.07*					2.43*	2.43*	5.65
5					4.21*	4.21*	3.66*	3.66*			2.29*	2.29*	6.30
4	6.56*	6.56*	5.26*	5.26*	4.63*	4.63*	4.32*	4.32*			2.24*	2.24*	6.72
3			6.33*	6.33*	5.20*	5.20*	4.62*	4.52			2.25*	2.25*	6.98
2			7.38*	7.38*	5.80*	5.80*	4.97*	4.44	3.08*	3.08*	2.31*	2.31*	7.09
1			8.11*	8.11*	6.30*	5.77	5.28*	4.37	2.96*	2.96*	2.43*	2.43*	7.05
0 (GROUND)			8.45*	8.25	6.62*	5.7	5.49*	4.33			2.63*	2.63*	6.87
-1	7.03*	7.03*	8.46*	8.23	6.70*	5.68	5.51*	4.32			2.95*	2.95*	6.52
-2	10.48*	10.48*	8.13*	8.13*	6.48*	5.7					3.50*	3.50*	5.99
-3			7.31*	7.31*							6.21*	6.21*	4.66

1. Load point is the end of the arm
2. Capacities marked with an asterisk (\*) are limited by hydraulic capacities
3. Lift capacities shown do not exceed 75% of minimum tipping loads or 87% of hydraulic capacities
4. The least stable position is over the side
5. The total mass of machine is 15000 kg included in this mass lower boom 1.85 m, upper boom 3.50 m, arm 2.10 m, 2,175 kg counterweight, bucket weight 0 kg all operating fluids a 75 kg operator.
6. Lift capacities are in compliance with ISO 10567

: Rating Over Front  
: Rating Over Side or 360 degree

# DX140W

Upper Boom: 11'6" (3,500 mm)  
 Lower Boom: 6'1" (1,850 mm)  
 Arm: 8'2" (2,500 mm)  
 Counterweight: 2.40 ton (2.18 metric ton)  
 Front OT Down + Rear OT Down

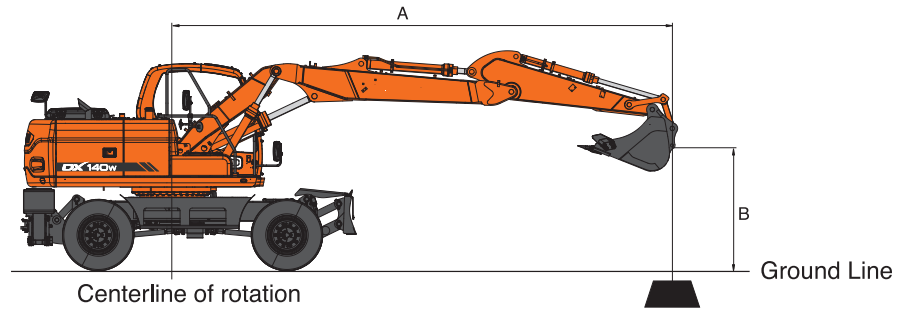

Feet Unit: 1,000 lb.

B (ft.) \ A (ft.)	10		15		20		MAX. REACH		A (ft.)
25			5.46*	5.46*			4.36*	4.36*	15.35
20					4.19*	4.19*	3.50*	3.50*	20.18
15			9.03*	9.03*	8.16*	8.16*	3.19*	3.19*	22.93
10			11.40*	11.40*	9.51*	9.51*	3.10*	3.10*	24.38
5			14.01*	14.01*	10.72*	9.48	3.18*	3.18*	24.74
0 (GROUND)	10.21*	10.21*	15.73*	14.47	11.66*	9.27	3.45*	3.45*	24.06
-5	17.16*	17.16*	16.12*	14.36	11.81*	9.22	4.01*	4.01*	22.24
-10	21.48*	21.48*	14.70*	14.54			9.15*	9.15*	18.55

Metric Unit: 1,000 kg

B (m) \ A (m)	3		4		5		6		7		MAX. REACH		A (m)
7					3.02*	3.02*					1.77*	1.77*	5.38
6							2.56*	2.56*			1.58*	1.58*	6.21
5					3.84*	3.84*	3.53*	3.53*			1.47*	1.47*	6.80
4			4.76*	4.76*	4.28*	4.28*	4.03*	4.03*	2.51*	2.51*	1.42*	1.42*	7.20
3			5.83*	5.83*	4.88*	4.88*	4.36*	4.36*	3.36*	3.36*	1.41*	1.41*	7.44
2			6.93*	6.93*	5.51*	5.51*	4.75*	4.45	3.91*	3.51	1.42*	1.42*	7.54
1			7.80*	7.80*	6.08*	5.78	5.10*	4.36	4.23*	3.47	1.47*	1.47*	7.50
0 (GROUND)			8.29*	8.23	6.47*	5.69	5.37*	4.31	3.93*	3.44	1.56*	1.56*	7.33
-1	6.30*	6.30*	8.45*	8.19	6.66*	5.64	5.49*	4.28	1.87*	1.87*	1.71*	1.71*	7.01
-2	8.96*	8.96*	8.27*	8.21	6.57*	5.65	5.34*	4.29			1.95*	1.95*	6.52
-3	9.93*	9.93*	7.68*	7.68*	6.07*	5.71					3.66*	3.66*	5.73

1. Load point is the end of the arm
2. Capacities marked with an asterisk (\*) are limited by hydraulic capacities
3. Lift capacities shown do not exceed 75% of minimum tipping loads or 87% of hydraulic capacities
4. The least stable position is over the side
5. The total mass of machine is 15000 kg included in this mass lower boom 1.85 m, upper boom 3.50 m, arm 2.5 m, 2,175 kg counterweight, bucket weight 0 kg all operating fluids a 75 kg operator.
6. Lift capacities are in compliance with ISO 10567

: Rating Over Front

: Rating Over Side or 360 degree



---

## NOTES

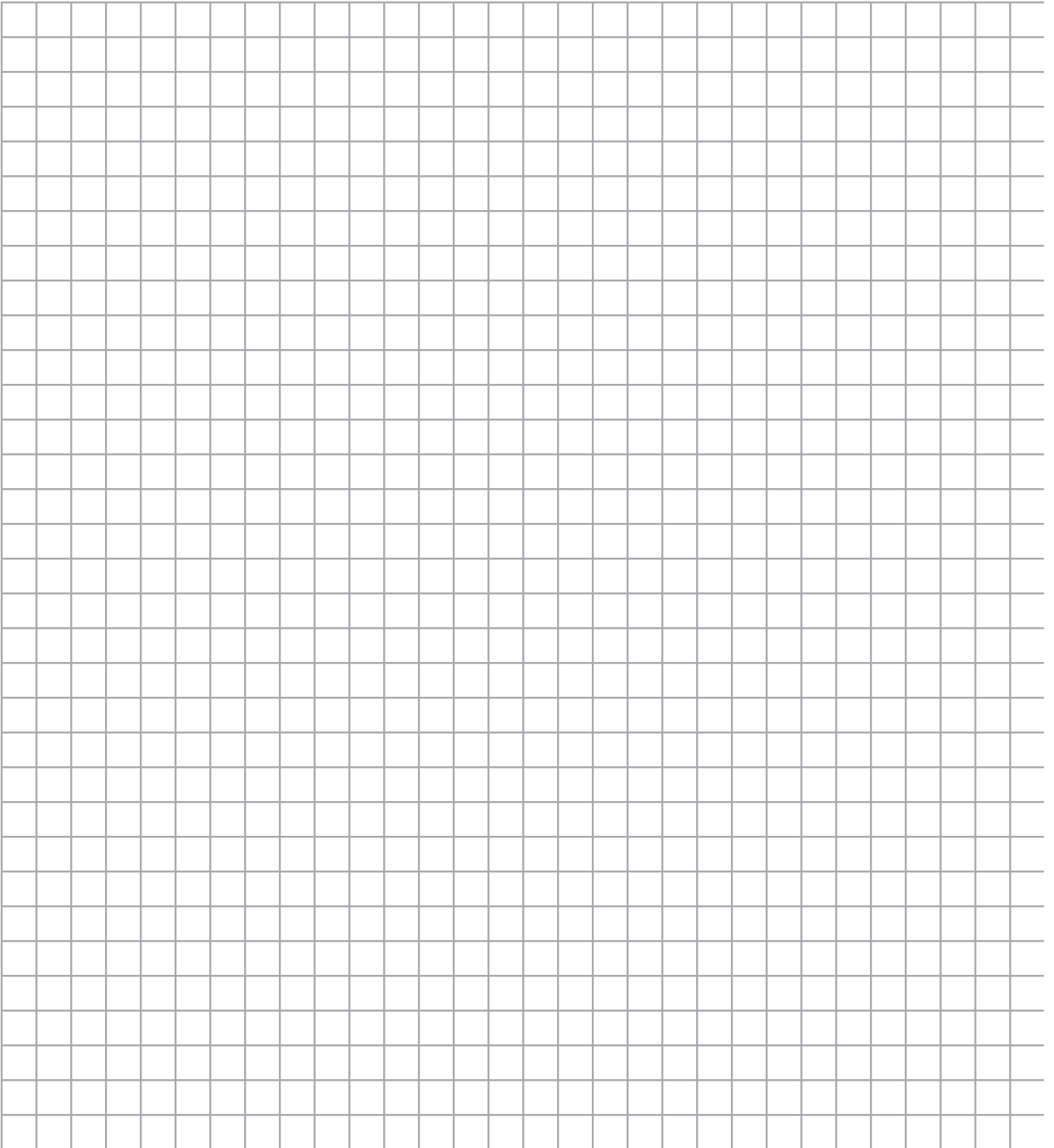



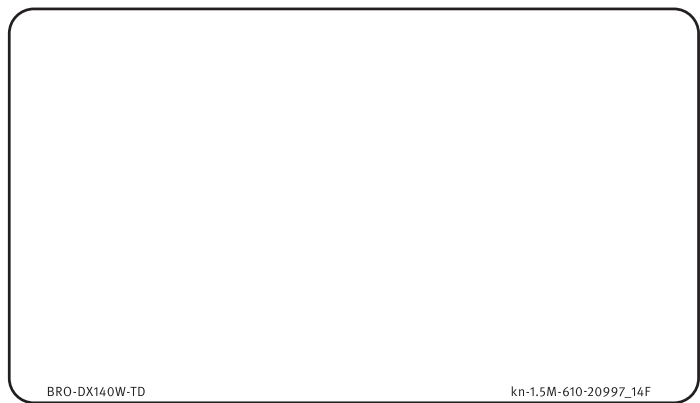

BRO-DX140W-TD

kn-1.5M-610-20997\_14F

For more information, call 1.888.323.9661,  
E-mail [InfoNow@dhiac.com](mailto:InfoNow@dhiac.com) or visit [www.infracore.com](http://www.infracore.com)



**Doosan Infracore**

© 2010 Doosan Infracore America – All rights reserved.